

Modular Cooking Range Line EVO700 Freestanding Gas Pasta Cooker, 1 Well 24.5 litres

ITEM # _____

MODEL # _____

NAME # _____

SIS # _____

AIA # _____



372090 (Z7PCGD1KF0)

24,5-lt gas pasta cooker with
1 well

Short Form Specification

Item No.

High efficiency 10.5 kW burners. Suitable for natural gas or LPG. Constant starch removal during the cooking process. The tank is pressed in AISI 316 stainless steel to protect against corrosion. Control panel with gas cock, piezo ignition. Manual water tap. Height adjustable feet in stainless steel. Exterior panels in stainless steel with Scotch Brite finish. One piece pressed work top in 1.5 mm thick stainless steel. Right-angled side edges to allow flush-fitting junction between units.

Main Features

- In addition to cooking pasta, the appliance can be used for noodles of every kind, rice, dumplings and vegetables.
- High efficiency 10.5 kW burners in stainless steel with flame failure device and optimized combustion, located below the well.
- No electrical connection needed.
- Water basin in 316 type Stainless steel.
- Provided with integrated drip zone on which baskets can be placed for draining purposes.
- 24.5 liters water basin.
- Unit to feature skimming zone for starch removal: improved water quality over time.
- Easy-to-use control panel with gas cock and piezo ignition.
- Safety thermostat to avoid operation without water.
- Continuous water filling regulated through a manual water tap.
- Large drain with manual ball-valve for fast emptying of well.
- **Automatic lifting system** (optional accessory): 200mm wide unit with two stainless steel basket supports, holding one GN 1/2 basket each, to be placed on either or both sides of machine to provide automatic lifting for four small portion baskets (to be ordered separately). Possibility to memorize nine cooking times through digital control.
- All major compartments located in front of unit for ease of maintenance.
- Unit delivered with four 50 mm legs in stainless steel as standard (all round Stainless steel kick plates as option).

Construction

- All exterior panels in Stainless Steel with Scotch Brite finishing.
- One piece pressed 1.5 mm work top in Stainless steel.
- Model has right-angled side edges to allow flush fitting joints between units, eliminating gaps and possible dirt traps.
- Water basin is seamlessly welded into the top of the appliance.
- IPx4 water protection.

Sustainability

- **ESD** available as accessory (installed separately): energy saving device uses heat produced by water drained through the overflow to pre-heat tap-in water up to 60°C, for constant water boiling.
- **EnergyControl**: unique feature for fine power adjustment to control boiling level and optimize energy consumption.

APPROVAL: _____

Included Accessories

- 1 of Door for open base cupboard PNC 206342

Optional Accessories

- Junction sealing kit PNC 206086
- Draught diverter, 120 mm diameter PNC 206126
- Matching ring for flue condenser, 120 -130 mm diameter PNC 206127
- 4 wheels, 2 swivelling with brake (EVO700/900). It is mandatory to install with base supports for feet/wheels. PNC 206135
- Flanged feet kit PNC 206136
- Frontal kicking strip for concrete installation, 400 mm PNC 206147
- Frontal kicking strip for concrete installation, 800 mm PNC 206148
- Frontal kicking strip for concrete installation, 1000 mm PNC 206150
- Frontal kicking strip for concrete installation, 1200 mm PNC 206151
- Frontal kicking strip for concrete installation, 1600 mm PNC 206152
- Frontal handrail 400 mm PNC 206166
- Frontal handrail 800 mm PNC 206167
- Frontal kicking strip, 400 mm PNC 206175
- Frontal kicking strip, 800 mm PNC 206176
- Frontal kicking strip, 1000 mm PNC 206177
- Frontal kicking strip, 1200 mm PNC 206178
- Frontal kicking strip, 1600 mm PNC 206179
- Large handrail (portioning shelf) 400 mm PNC 206185
- Large handrail (portioning shelf) 800 mm PNC 206186
- Frontal handrail 1200 mm PNC 206191
- Frontal handrail 1600 mm PNC 206192
- 4 feet for concrete installation (not for 900 line freestanding grill) PNC 206210
- Right and left side handrails PNC 206240
- Pair of side kicking strips PNC 206249
- Pair of side kicking strips (concrete installation) PNC 206265
- Chimney upstand, 400 mm PNC 206303
- Flue condenser for 1/2 module, 120 mm diameter PNC 206310
- 2 side covering panels, height 700 mm, depth 700 mm PNC 206319
- Door for open base cupboard PNC 206342
- Energy saving device for pasta cookers PNC 206344
- Automatic programmable basket lifting system for 24.5lt pasta cookers, 2 lifters PNC 206354
- Base support for feet or wheels - 400mm (EVO700/900) PNC 206366
- Base support for feet or wheels - 800mm (EVO700/900) PNC 206367
- Base support for feet or wheels - 1200mm (EVO700/EVO900) PNC 206368
- Base support for feet or wheels - 1600mm (EVO700/900) PNC 206369
- Rear paneling - 600mm (EVO700/900) PNC 206373
- Rear paneling - 800mm (EVO700/900) PNC 206374

- Rear paneling - 1000mm (EVO700/900) PNC 206375
- Rear paneling - 1200mm (EVO700/900) PNC 206376
- Frame for 2 pasta cooker baster (700) PNC 206396
- Chimney grid net, 400mm PNC 206400
- Base support for feet/wheels (600mm) PNC 206431
- Kit G.25.3 (NI) gas nozzles for 700 and 900 pasta cookers PNC 206465
- 2 baskets, left and right (105x160x240) for pasta cookers - EVO700 PNC 921020
- 2 baskets, left and right (105x105x240) for pasta cookers - EVO700 PNC 921021
- False bottom (230x350x60) for pasta cooker baskets - EVO700 PNC 921022
- Lid for 24,5lt pasta cookers PNC 921607
- 2 half size baskets (220x170x240) for 24,5lt pasta cookers - EVO700 PNC 921610
- Full size basket (220x350x240) for pasta cookers - EVO700 PNC 921611
- 2 half size baskets 105x350 for pasta cookers for 24,5lt pasta cookers PNC 921619
- Pressure regulator for gas units PNC 927225

Modular Cooking Range Line EVO700 Freestanding Gas Pasta Cooker, 1 Well 24.5 litres

Front

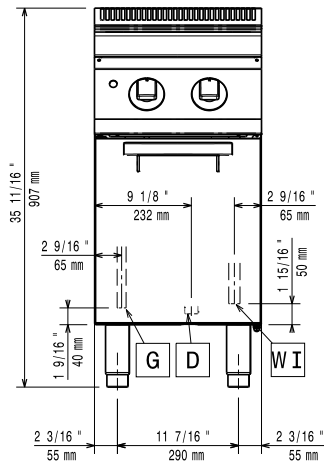

Side

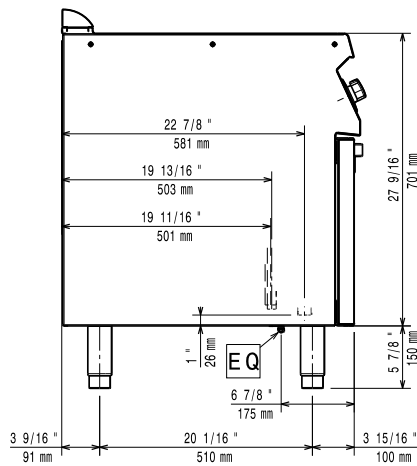

- D** = Drain
- EQ** = Equipotential screw
- G** = Gas connection
- WI** = Water inlet

Top

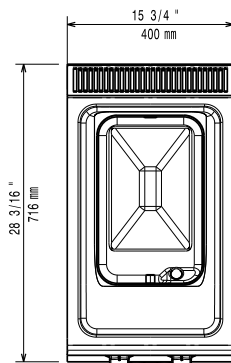

Gas

Gas Power:	11.5 kW
Standard gas delivery:	Natural Gas G20 (20mbar)
Gas Type Option:	LPG
Gas Inlet:	1/2"

Water:

Total hardness:	5-50 ppm
Drain "D":	1"
Incoming Cold/hot Water line size:	1/2"

Electrolux Professional recommends the use of treated water, based on testing of specific water conditions.

Please refer to user manual for detailed water quality information.

Key Information:

If appliance is set up or next to or against temperature sensitive furniture or similar, a safety gap of approximately 150 mm should be maintained or some form of heat insulation fitted.

Usable well dimensions (width):	250 mm
Usable well dimensions (height):	300 mm
Usable well dimensions (depth):	400 mm
Well Capacity (MAX):	24.5 lt MAX
Net weight:	50 kg
Shipping weight:	47 kg
Shipping height:	1130 mm
Shipping width:	460 mm
Shipping depth:	820 mm
Shipping volume:	0.43 m ³
Certification group:	N7ECPG

Modular Cooking Range Line
EVO700 Freestanding Gas Pasta Cooker, 1 Well 24.5 litres

The company reserves the right to make modifications to the products without prior notice. All information correct at time of printing.